



Jeep J8[®]

The Icon Returns

JGMS
JEEP
GOVERNMENT &
MILITARY SALES



The Icon Returns to Service

Jeep returns to active duty with the J8 utility vehicle for government and military service, setting new standards for toughness, reliability and safety on and off-road. Starting with the legendary Jeep Wrangler, a special team of Jeep engineers created the toughest and most capable Jeep ever built for the world's most demanding customers.

Extensive testing has been conducted using a gruelling off-road duty cycle at the famed National Automotive Testing Center (NATC) in Nevada, U.S.A. The J8 features:

- 3 and 5-door versions in left and right-hand drive on a long wheelbase
- A powerful and efficient 2.8 L Turbocharged Diesel engine matched with automatic transmission, Command-Trac® 4WD and Euro V or unregulated emissions
- Heavy-duty air cooling, brakes, suspension and a sturdy Dana 60 rear axle
- Significant reinforcement of chassis for outstanding payload and towing capability
- Modern safety equipment including ABS brakes, optional driver and front passenger airbags and a wide stance to grip the road

The J8's interior was designed with safety and ergonomic ease in mind for government and military customers, featuring comfortable vinyl seats, generous storage space and a range of specialized options for communications and other equipment.

To create a family of specialized applications for government and military fleets, we turned to a world leader in engineering and design innovation and integrated protection systems, The Jankel Group. Specialized applications include:

- **Light Patrol and Border Patrol**
- **Personnel Carrier**
- **Cargo / Comms**
- **Discreet and Military Armored**
- **Ambulance**
- **Pick-up**

Every J8 is backed by a full manufacturer's warranty. The global network of Jeep dealers and JGMS's integrated logistics support team are available to ensure outstanding customer support.

Jeep J8. The icon is back.





3-DOOR / 5-DOOR JEEP® J8 - STANDARD VEHICLE

Jeep J8

Mission and Performance

The Jeep® J8 standard models are available in 3-door (2 person) and 5-door (5 person) configurations. Both J8 standard models offer impressive payload and towing capability, legendary off-road performance and adaptability to a wide range of missions. Safety features include reliable 5-speed automatic transmission, four-wheel disc brakes with ABS, a wide stance for superb stability and airbags for driver and front passenger.

- Left or right-hand drive configurations
- 2.8 L Turbo Diesel (4 cylinder) with Euro V or unregulated emissions
- 145 kW (194 bhp) @ 3,800 rpm; 460 Nm (339 lb-ft) @ 1,800 rpm
- Automatic transmission with Overdrive
- Four-wheel disc brakes with ABS
- Command-Trac® part-time 4WD, 2.72:1 low range ratio
- Payload of 1,164 kg (2,566 lb); enhanced payload of 1,664 kg (3,668 lb) available
- Enhanced air filtration system, desert rated for 5 hours at zero visibility
- Range of 630 - 930 km (391 - 578 miles)

Optional Equipment

- Air conditioning
- Euro V emissions
- Heavy-duty hard or soft top
- 12 V / 24 V electrical system
- Other options as required by customer





JEEP® J8 LIGHT PATROL VEHICLE

Jeep J8

Mission and Performance

The Light Patrol Vehicle (LPV) is a capable and flexible 3-door platform designed for surveillance and reconnaissance, base patrol and rapid offensive actions. The LPV is equipped with a standard traversing ring, weapon mounts, storage systems and can be equipped with zoned armor.

- Based on 3-door J8 with robust frame system integrated into vehicle chassis and fitted with Payload Enhancement Kit (PEK)
- 3-man vehicle with modular storage systems
- Rear traversing ring with mount for 7.62 mm MG / .50 cal MG / 40 mm AGL and universal ammunition box holders
- Front elevating commander's seat with swing arm weapon mount
- Front half doors with removable upper section and fully removable soft top
- Operational payload of approximately 1,264 kg (2,787 lb) and GVW of 3,864 kg (8,518 lb)
- Air transportable by fixed wing and helicopter

Standard Equipment

- Winch bar and front wing protection bars with winch
- Light protection grilles and additional driving lamps
- Shatterproof, folding and removable mirrors
- Fitting for radio systems between seats
- Blackout and IR lighting
- Other options as required by customer





JEEP® J8 BORDER PATROL VEHICLE

Jeep J8

Mission and Performance

The Border Patrol Vehicle (BPV) is a capable and flexible 5-door platform designed for surveillance and reconnaissance, base patrol and rapid offensive actions. The BPV is equipped with a standard traversing ring, weapon mounts, storage systems and can be equipped with zoned armor.

- Based on 5-door J8 with robust frame system integrated into vehicle chassis and fitted with Payload Enhancement Kit (PEK)
- 4-man vehicle with modular storage systems
- Rear traversing ring with mount for 7.62 mm MG / .50 cal MG / 40 mm AGL and universal ammunition box holders
- Front elevating commander's seat with swing arm weapon mount
- Half doors with removable upper section and fully removable soft top
- Operational payload of approximately 1,164 kg (2,566 lb) and GVW of 3,864 kg (8,518 lb)
- Air transportable by fixed wing and helicopter

Standard Equipment

- Winch bar and front wing protection bars with winch
- Light protection grilles and additional driving lamps
- Shatterproof, folding and removable mirrors
- Fitting for radio systems between seats
- Blackout and IR lighting
- Other options as required by customer





JEEP® J8 PERSONNEL AND CARGO CARRIER

Jeep J8

Mission and Performance

Fitted with a standard heavy-duty soft top and raised roof, the J8 is the backbone of a military transport fleet. As personnel transporter, the J8 comfortably seats driver, front passenger as well as a crew of 6. Folding and removable rear seats allow additional cargo transport. With seats folded, the vehicle can accommodate a NATO pallet load.

- Based on 3-door J8 with robust tubular cage integrated into vehicle chassis for enhanced occupant protection
- Seating for 8; 6 crew in rear on lateral bench seating
- Bench seat folds away for cargo and carrier role

Optional Equipment

- Payload Enhancement Kit (PEK) raises payload to approximately 1,594 kg (3,514 lb)
- Heavy-duty hard top
- Individual seating with safety belts
- Heavy-duty winch
- Internal storage and lighting systems
- Other options as required by customer





Mission and Performance

Jeep J8 offers two armored vehicles for different requirements, with ballistic and blast certification from Germany's Beschussamt:

- An overtly armored military vehicle specially tailored for patrol, staff and infrastructure protection and peacekeeping missions.
- A discreetly armored vehicle for the protection of diplomats, aid workers and other high-risk individuals, as well as for VIP escort duties.

Both armored vehicles replace the original body with hot-formed ballistic steel shaped to the precise contours of the J8. This innovative technology delivers optimal ballistic and blast protection at reduced weight and cost. J8 armored vehicles are equipped with a payload enhancement kit (PEK) for GVW of 3,864 kg (8,518 lb) and approximately 500 kg (1,102 lb) of payload. Standard equipment includes armored fuel tank, 50 km (31 miles) run flat system and deadbolt door locks.

Protection Level

- Beschussamt certified ballistic protection to BRV 2009/VR7: 7.62 x 51 FJ/PB/SC (830+/- 10m/s); 5.56 x 45 FJ/PB/SCP (950+/- 10m/s) at 360 degrees.
- Beschussamt certified blast protection to ERV 2010: underbody (1 x M67 / HG85), roof (1 x DM51) and side blast (12.5 kg PETN @ 4m).

Optional Equipment

- Winchbar and winch
- Roof hatch for situational utility / escape
- Discreet strobe lights front and rear
- Exhaust anti-insert modification
- Communications systems preinstalled
- Special paint (IR / anti-flame etc.)
- Original Jeep rails, bumpers and alloys
- Trim ranges from military to luxury VIP
- Other equipment available upon request



INTEGRATED LOGISTICS SUPPORT PLAN



Comprehensive Customer Support

JGMS harnesses the capabilities of over 4000 Jeep® dealers around the globe to create a comprehensive customer support network for Jeep J8. We design support solutions tailored to customer needs: from spare parts supply to an integrated logistics package that manages the support burden across a full range of operational areas.

Training

JGMS develops training programs by applying needs analysis in the field, where it counts most, to provide customized training programs:

- Courses can be offered in-country and in local language or at regional training centers
- Technical training ranges from basic vehicle systems and maintenance to complete overhaul and remote diagnosis using StarMOBILE® Remote Connectivity internet-based software
- All training materials can be provided in-language consistent with customer standards

Local Assembly

J8 specialized modifications have been developed for local assembly, providing significant employment opportunities in customer countries. JGMS provides assembly instructions and process documents, trains and supervises local staff in assembly operations, and inspects vehicles pre-delivery to validate the full vehicle warranty.

Warranty

JGMS works in close cooperation with Jeep Engineering, and a manufacturer's warranty covers our full family of J8 specialized applications.

Technical Publications

Vehicle projects are delivered with support publications to enable efficient vehicle fleet management and maintenance. JGMS understands the cost of fleet downtime, and our technical publications enable maintenance staff to sustain high fleet availability. Publications range from user handbooks to full scale military publications. Authored in English, all publications can be translated and are available in print and electronic format for:

- Jeep J8 repair manual, user handbook, parts catalogue
- JGMS workshop and operator manuals
- JGMS illustrated spare parts catalogues

Service and Parts

J8 vehicles benefit from the already existing Jeep worldwide service and parts support network, and from the many parts shared with the popular Jeep Wrangler. Advantages of the Jeep network include:

- In-country vehicle inspections prior to delivery
- Access to parts from national and regional warehouses improves availability and reduces inventory cost
- Access to local Jeep workshop training and advisory programs
- Customer enrollment as Jeep dealer, with full access to service updates, technical bulletins and parts ordering, or a fleet maintenance contract through local dealer distributor

SPECIFICATIONS AND STANDARD EQUIPMENT

Jeep J8

Specifications (Utility Vehicle)

Drivetrain

VM Motori **2.8 L Turbo Diesel** (4 cyl)

Max Power

145 kW (194bhp) @ 3,800 rpm

Max Torque

460 Nm (295 lb-ft) @ 2,000 rpm

Euro V or Unregulated Emissions

Dimensions

Total Length **4,632 mm** (182 in)

Maximum Width **1,880 mm** (74 in)

Maximum Height **1,762 mm** (69 in)

Wheelbase **2,946 mm** (116 in)

Turning Radius **6.2 m** (24 in)

Fording Depth **762 mm** (28 in)

Ground Clearance **231 mm** (9 in)

Capacity

Fuel Tank **83.3 Liters** (22 gallons)

Economy **8.9 L / 100 km** (26.4 mpg)
(Euro V, extra urban)

Range

Range **630 - 930 km** (391 - 578 miles)

Max Speed **140 kph** (87 mph)

Angles

Approach Angle **44.4°**

Departure Angle **40.5°**

Breakover Angle **22.0°**

Incline **45° Grade** (hard surface)

Side Slope Angle **35°**

Weights

Curb Weight **2,200 kg** (4,850 lb)

Gross Vehicle Weight **3,364 kg** (7,416 lb)

Payload **1,164 kg** (2,566 lb)

1,664 kg (3,667 lb) with PEK

Towing Max. **3,500 kg** (7,716 lb)

Standard Equipment

Engine - 2.8 L Turbo Diesel

Steering - Hydraulic with recirculating ball

Brakes - Four wheel disc with ABS

Emissions - Unregulated

Transmission - 5-speed auto with overdrive

4WD System - Command-Trac® Part-time

4WD Ratio - 2.72:1 low range ratio

Axle - Front - Dana 44; Rear - Dana 60

Differential - Limited slip on rear axle

Suspension - Front coil springs, rear leaf springs

Electrical - 12 V (180 amp alternator)

Roof - Open, no top

Windshield - Folds down onto hood

Doors - Half doors with vinyl window insert

Cooling - Severe use

Air-Induction - Desert rated 5-hours at zero visibility

Wheels - 17" steel with 245/70 R17 BF Goodrich tires

Mirrors - Exterior left and right

Airbags for driver and passenger

Spare tire and wheel

Vinyl seats

Armrest with stowage compartment

Glove compartment

Headrests for driver and front passenger

4-speed fan with variable temperature control

Illuminated instrument cluster

Sun visor for driver and passenger

Warning lamps for engine oil and coolant water level

Water drain plugs located on floor

3-point safety belts

Heavy gauge steel bumpers

Shackles for airlift and towing; rear pintle hook for towing

Fuel filter with water separator

Spare tailgate wheel bracket with

reinforced mounting plus full sized spare wheel

Frame reinforcement brackets of high strength steel

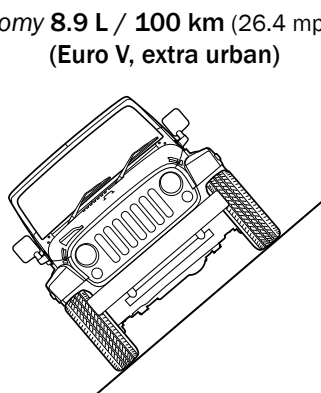

Side Slope Incline (Hard Surface) 35°

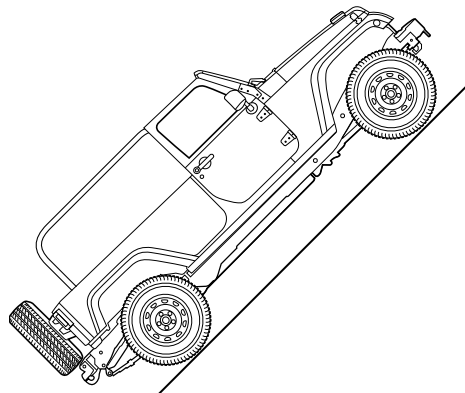

Grade Incline (Hard Surface) 45°

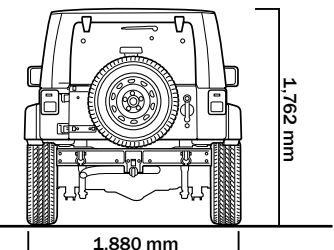
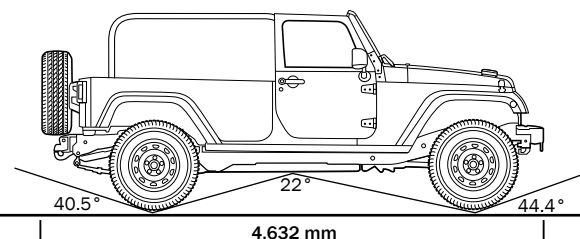

JEEP® J8 VARIANTS

Jeep J8

3-Door Jeep

5-Door Jeep

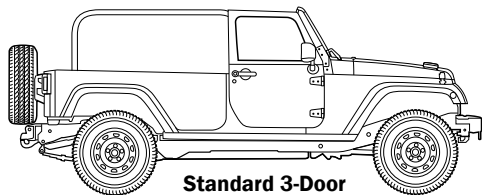

Standard 3-Door

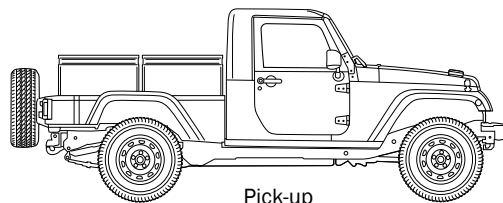

Pick-up

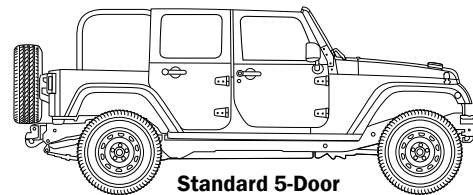

Standard 5-Door

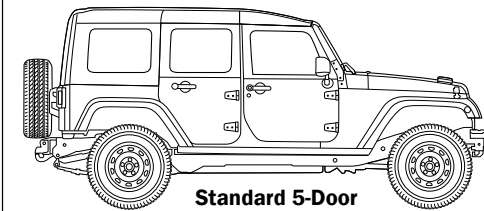

Standard 5-Door
+ Heavy Duty Hard Top

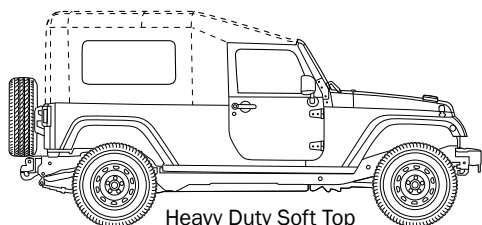

Heavy Duty Soft Top
- Personnel / Cargo Carrier

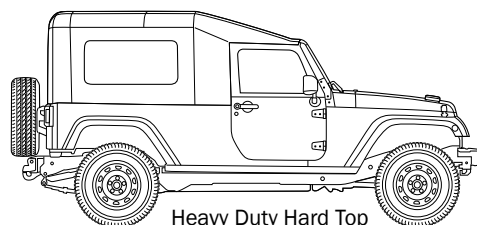

Heavy Duty Hard Top
- Personnel / Cargo Carrier

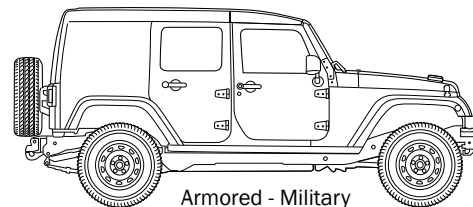

Armored - Military

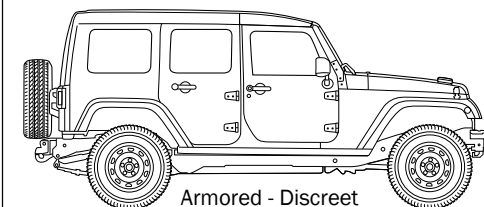

Armored - Discreet

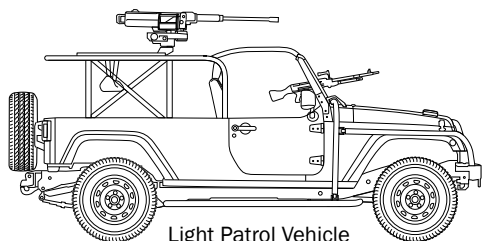

Light Patrol Vehicle

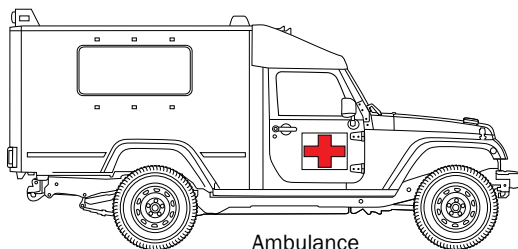

Ambulance

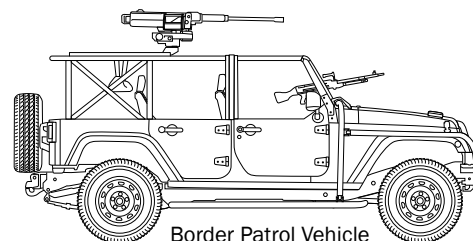

Border Patrol Vehicle

UK Office

PO Box 1, Weybridge, Surrey, KT13 8XR, United Kingdom
T 00 44 (0) 1932 857766 F 00 44 (0) 1932 855694
info@jgms.com

US Office

190 Parkway West, Suite 100, Duncan, SC 29334, U.S.A.
T 00 1 864 721 2986 F 00 1 864 721 2987
info@jgms.com

www.jgms.com

January 2011 v3.1

© Jeep Government and Military Sales 2011

JGMS reserves the right to make changes to the J8 design and equipment.

All data in this brochure should be regarded as approximate.